

In dialisi o in ogni
altra situazione
clinica ottimale,
l'esercizio fisico è vita.

*During dialysis
treatment and in other
proper clinical situation,
exercising means life.*



TherapyBike

gb
Gardhen balance

TherapyBike

TherapyBike è realizzato affinché tutti, sotto il controllo medico, possano fruire dei benefici effetti ottenibili con l'esercizio fisico.
Therapybike is designed to make all the patients able to take advantages from workout, even under medical control.

Si adatta alla gran parte delle poltrone.
It's adaptable to most kind of chairs through friendly operations.



Questo dispositivo è accessibile a persone di ogni età, peso e statura.
Designed for patients of all age, weight and height.



Due motori lineari a bassa tensione, azionabili con pulsantiera, accostano i pedali al paziente, regolando altezza e profondità, fino a ottenere la corretta postura.

Two low voltage motors, activated by handset, put the pedals closer to the patient, adjusting the height and the depth until finding the proper position.



TherapyBike è dotato di 2 ruote funzionali al trasferimento da luogo a luogo. Leggero e perfettamente bilanciato può essere guidato da chiunque senza alcuno sforzo.

Therapybike is equipped with 2 wheels that help people moving it room-to-room. Light and well balanced, it can be moved by everyone in a very easy way.



Con alcune semplici operazioni assistite si adatta alla persona, pronta per l'uso.
It's adaptable to most kind of chairs through friendly operations.



Adattamento in lunghezza / *Adaptation in length*



Adattamento in altezza / *Adaptation in height*

L'idea di posizionare la poltrona sul telaio, assicura grande stabilità all'intero dispositivo, evitando al paziente sgradevoli sensazioni di instabilità durante la pedalata.

The chair is positioned on the bike frame assuring good stability avoiding wobbling feeling during the biking.



È possibile quindi procedere con una pedalata attiva, dolce, in autonomia propria (active biking), oppure impostare una pedalata assistita (passive biking), regolabile nell'intensità.

It can be used in self-biking (active biking), or with a motor-biking (passive biking) with speed regulation.

Dimensioni

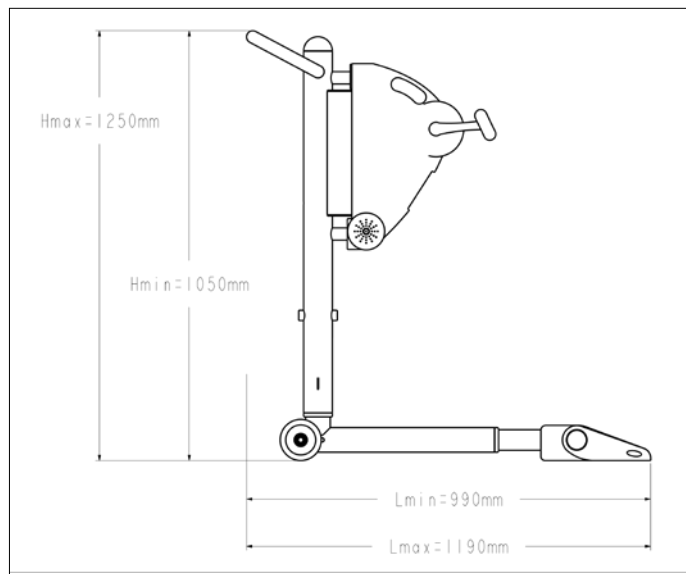

Dimensions

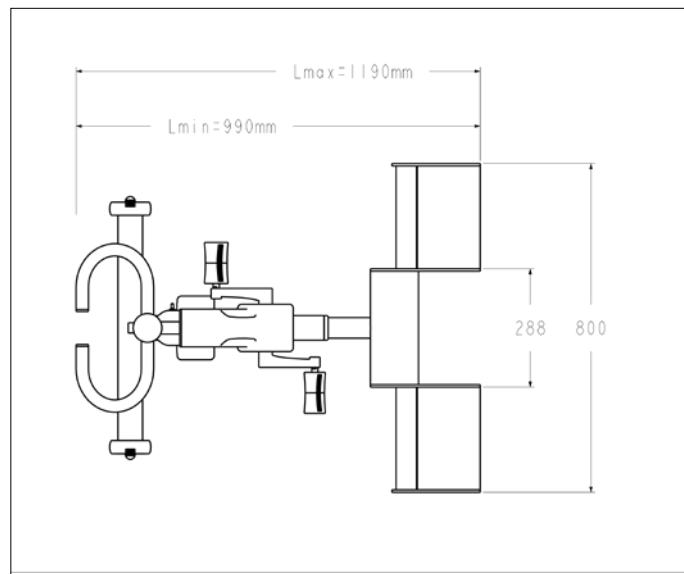

Dati

Telaio in acciaio zincato e verniciato a polveri termoindurenti

Peso totale	33 kg
Alimentazione	230 Vac 50/60 Hz
Motori elettrici	bassa tensione (24 V)
Assorbimento max	350 VA
Isolamento	IP44
Carico di lavoro sicuro	200 kg
Ruote inossidabili	di diametro 100 mm
Colore di serie	ral 2004 (arancio)

Il dispositivo è reso già montato e pronto all'uso completo di:

- pedali e relative fasce di contenimento
- cuscino di avvicinamento per pazienti piccoli
- istruzioni d'uso
- imballo
- certificato di garanzia
- dichiarazione di conformità

Copiosa è la letteratura scientifica di supporto

Data

Epoxy powdercoated and galvanized steel frame.

Total weight	33 kg
Power	230 Vac 50/60 Hz
Electric motors	low voltage (24 Volt)
Max electrical input	350 VA
Insulation	IP44
Max load	200 kg
Stainless steel wheels	diameter 100mm
Serial color	ral 2004 (Orange)

The device is delivered formerly assembled, ready to use, complete of:

- pedals and related containment swathes
- cushion useful for little patients
- instruction manual
- packaging
- certificate of guarantee
- declaration of conformity

Scientific literature is available

Le immagini riprodotte in questa scheda sono puramente indicative. È facoltà del produttore apportare modifiche ai progetti senza alcun preavviso.
The projects pictures in this sheet may be subject to subsequent design improvements. The manufacturer reserves the right to modify the projects without notice.

Sistema certificato di gestione aziendale per la qualità - Quality certifications



Dispositivo medico conforme
93/42/CEE e s.m.i.
Medical device 93/42/EEC compliant
and its revised version

Per l'identificazione degli allestimenti riferirsi al catalogo accessori e/o alle proposte commerciali. In caso di dati discordanti fa fede il contenuto delle proposte commerciali.
For the accessories identification please refer to the accessories catalogue and/or to the commercial offers. When the data are different please refer to commercial offer.